

**Cameroun 2010-2012:**

**Project A:** Construction of a 60.000m<sup>2</sup> Palm oil factory 30T/hr, with a 20T/hr steam boiler and 1,8MW power turbine incl. effluent treatment ponds.

Budget: 20 million US\$

Scope: Turn-key project: design, study & complete project management.

**Project B:** Housing and facilities for 1,000 people.



Pure oil storage and decantation station.



Fiber and boiler feeding station.

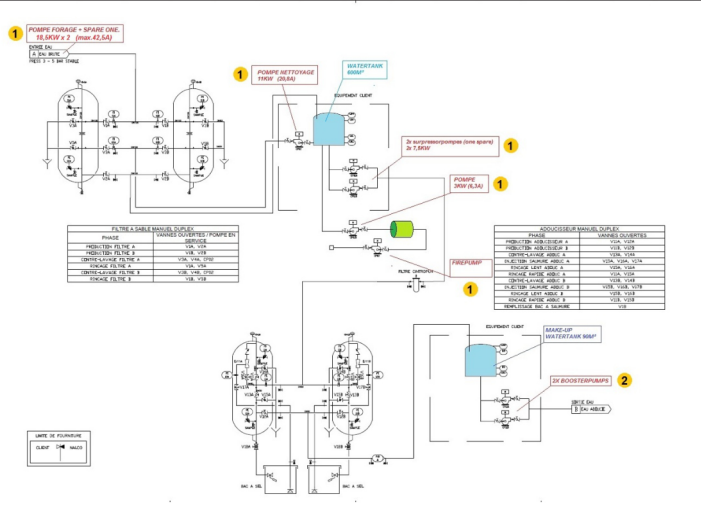

Water treatment station for boiler and production process.



Water softeners for water treatment station. (Nalco)



Drilling of several boreholes for water provision for the villages.



Welding of 2 x 2000T oil tanks, 2 x 300T Kernel silo and 10m<sup>3</sup> watertower.



Installation of a Atmind 20T/Hr boiler on biomass.



Building foundations for prefabstructure and groundworks.